

# ESD(/HG)-1691.0-137.5

*Pre-select Filtered Low Noise L-band Block Downconverter*

---



## *Features*

- Pre-select filter to reduce cellular phone and radar interference
- Low noise figure, 1.2 dB(92 K) typical
- Conversion gain, 52 dB typical
- Higher gain version available (special order)
- High stability phase locked oscillator
- Temperature stability, +/- 2.5 ppm
- Low phase noise
- O-ring sealed 'N' connectors
- Weatherproof O-ring sealed machined aluminum case

## *Applications*

- Meteosat Second Generation (MSG) HRIT, LRIT and existing Meteosat PDUS reception
- GOES GVAR and LRIT reception
- MTSAT HiRID, HRIT, LRIT and existing GMS S-VISSR reception

## *Description*

The next generation of international geosynchronous weather satellites, including Europe's MSG (Meteosat Second Generation) and Japan's MTSAT (Multi-functional Transport Satellite), have been designed to provide users with upgraded data quality and quantity by implementing improved high and low speed digital downlinks based on industry standard protocols. Additionally, the radio spectrum utilized by these satellites is becoming increasingly valuable and crowded with new users. Of particular concern is the proliferation of cellular telephone transmitters on adjacent frequencies which present potential sources of interference.

The ESD-1691 has been specifically designed for these new digital formats and harsh radio environments.

The ESD-1691 incorporates a custom dielectric preselection filter to reduce the susceptibility to intermodulation due to powerful adjacent cellular transmitters while providing necessary sensitivity for satellite data reception. Typical receive system noise temperatures of 130K and G/T of 13dB/K can be expected when using the ESD-1691 with a good quality 12 ft (3.7 m) antenna and the Quorum SFD-1691L scalar feed.

The ESD-1691 is a block downconverter that incorporates a phase locked and temperature compensated local oscillator. The low phase noise of the ESD-1691 is essential for quality reception of the downlinked digital data.

Satellite data reception front ends constructed from the ESD-1691, SFD-1691L and the Quorum MetCom DSP Receivers have been engineered to provide the ultimate in reliable performance from existing and next generation weather satellites.

**Specifications** (subject to change without notice)

**Electrical**

|                                      |  |
|--------------------------------------|--|
| Noise Figure.....                    | 1.2 dB (92 K) typical  |
| Input Frequency.....                 | 1691.000 MHz   |
| Local Oscillator Frequency.....      | 1553.500 MHz   |
| Output Frequency.....                | 137.500 Mhz  |
| Preselect Filter.....                | 3 pole, -3dB @ 120 Mhz<br>-20 dB @ 280 MHz                           |
| Converted Bandwidth.....             | 50 MHz @ 3 dB typical  |
| Conversion Gain standard model.....  | >50 dB, 52 dB typical  |
| Conversion Gain high gain model..... | >70 dB, 72 dB typical  |
| Image Rejection.....                 | >80 dB, 90 dB typical @ 1416 MHz                                     |
| Input / Output Impedance.....        | 50 ohms  |
| Output 1dB Compression Point.....    | >+10 dBm   |
| Local Oscillator Stability.....      | ±2.5 ppm (-30 to +60 C)  |
| Local Oscillator Type.....           | Internal PLL locked to TCXO  |
| Phase Noise.....                     | -94 dBc/Hz @ 10 KHz typical<br>-114 dBc/Hz @ 100 KHz typical         |
| Input Voltage.....                   | +10 to +15 VDC @ 350 ma typical<br>Power provided on IF output cable |

**Environmental**

|                              |                             |
|------------------------------|-----------------------------|
| Temperature (operating)..... | -40 to +140 F (-40 to 60 C) |
| Humidity.....                | 100%                        |

**Mechanical**

|                   |   |
|-------------------|---|
| Connectors.....   | Type 'N' female   |
| Size.....         | 4.21" x 2.53" x 1.11"<br>(107.4 mm x 64.3 mm x 28.0 mm) |
| Weight.....       | 0.9 lb (0.4 kg)   |
| Construction..... | Machined Aluminum Case, O-ring sealed, painted white    |

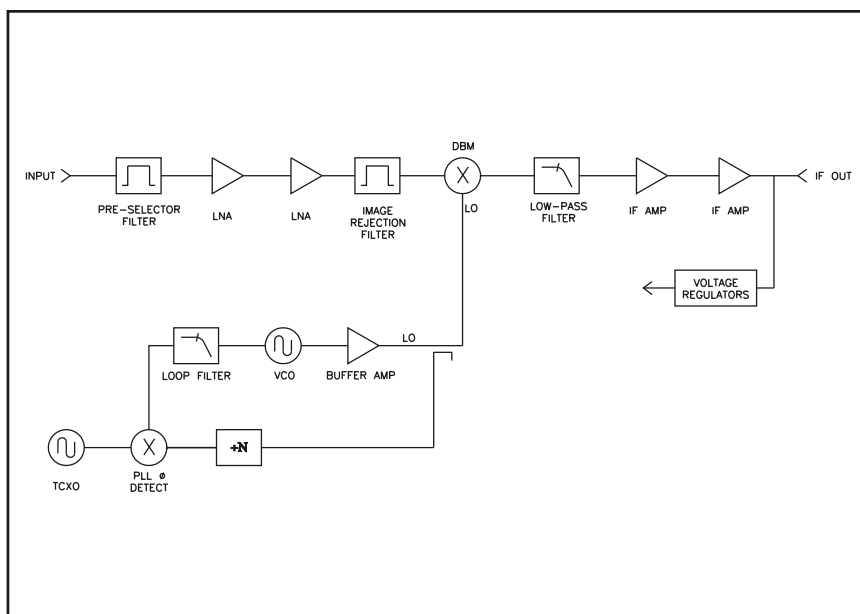

ESD-1691.0-137.5 L-band Downconverter Block Diagram

**System Usage Notes**

A typical Quorum Communications system for the reception of geosynchronous meteorological satellite high speed digital downlinks such as MSG HRIT or GOES GVAR would pair the **ESD-1691.0-137.5 Block Downconverter** with the Quorum **SFD-1691L high efficiency Scalar Feed**. The feed and downconverter would be mounted to a commercial quality 3.0 to 3.7 meter (10 to 12 foot) antenna such as the Prodelin 1300 series. This system with a 3.7m antenna would provide a typical system G/T of 13 dB/K.

The output of the downconverter would be connected to a Quorum **MetCom DSP Second Generation Receiver**. The MetCom DSP receiver provides state of the art demodulation using *Digital Signal Processing* techniques. In addition, the MetCom DSP can be configured to support a single downlink type or all of the current downlinks in a single unit. The MetCom DSP is housed in a PC friendly drivebay format for easy installation in most PC or Workstation enclosures.

PC and workstation based systems based on the Quorum Scalar Feed, ESD Downconverter and MetCom DSP Receivers are available from many suppliers worldwide.